

A DYNAMIC ELECTROTHERMAL ANALYSIS TECHNIQUE BASED ON DIELECTRIC MEASUREMENTS*

JEN CHIU

Plastics Department, E.I. du Pont de Nemours & Company, Wilmington, Del. 19808 (U.S.A.)

(Received 13 June 1973)

ABSTRACT

A dynamic electrothermal analysis technique is described, which utilizes dielectric measurements for materials characterization. With milligram amounts of sample, both capacitance and dissipation factor are measured continuously and automatically as a function of temperature in a range from -190 to 500°C . Thus, dielectric properties are used for analysis in a way similar to differential thermal analysis. Some applications of this technique are illustrated.

INTRODUCTION

Electric properties, including resistivity, dielectric constant, and dissipation factor, are important in evaluation and use of many materials, particularly semiconductors, insulations, plastics, and elastomers. However, aside from using such electric parameters for performance evaluation, the potential of utilizing changes in electric behavior as a means of analysis of the material, elucidation of structure, and study of morphological aspects has not been well recognized. A quick glance at the vast amount of literature containing electrical data supports the view that much of the information can be used for analytical purposes, and the main reason for not doing so may be the reluctance of the researcher to rely on the slow and tedious test equipment and procedures presently used in a physical testing laboratory. This situation could rapidly change, if a compact, convenient bench instrument should become available with features of fast and continuous measurement, flexibility in varying temperature and environment, automatic presentation of data, and easy handling of samples. Such a dynamic electrothermal analysis (ETA) technique is then used in a way very similar to differential thermal analysis (DTA) and differential scanning calorimetry (DSC) which have been replacing classical calorimetry in numerous applications.

Techniques and applications of ETA in the direct current (d.c.) mode or resistivity measurement have been discussed briefly by Wendlandt¹ and Garn². The use of such techniques for polymer studies has been reviewed by Warfield³ and Seanor⁴.

*Presented at the 4th North American Thermal Analysis Society Meeting, Worcester, Mass., June 13–15, 1973.

More recent developments on ETA are included in biennial reviews by Murphy⁵ and Mitchell and Chiu⁶. Undoubtedly, ETA in the d.c. mode is being increasingly used.

Dielectric measurements as a function of temperature performed in a dynamic way or ETA in the alternating current (a.c.) mode are not as common, although a large wealth of information is available in the literature reporting such curves constructed from manually taken points. Only recently, several laboratories began to use modern thermal instrumentation to obtain thermograms continuously and automatically upon variation of sample temperature in a programmed fashion. Dielectric measurements on acrylics were made at 60 Hz over a temperature range of -40 to 200°C for elucidation of structure and stereoregularity⁷. Sacher⁸ studied relaxations of poly(ethylene terephthalate) using a continuous recording bridge. Yalof and Wrasidlo⁹ reported dielectric studies to correlate with DTA and other thermal methods. Hedvig and coworkers^{10,11} employed a continuous recording dielectric apparatus to study polymer degradation, molecular mobility, and curing reactions. Galand¹² measured dielectric properties of polymers automatically as a function of temperature and frequency. Other applications of dynamic dielectric measurements are reviewed biennially by Mitchell and Chiu⁶.

ETA, operated in either the dc or ac mode, has been shown to have the following applications: (1) electrical parameters followed as a function of temperature; (2) study of physical transitions; (3) structure elucidation; (4) study of degradations, polymerization, curing, and other reactions; (5) study of effects of moisture, plasticizers, fillers, etc. and possible analysis of these materials in a matrix; (6) miscellaneous studies such as gas adsorption, irradiation, crosslinking etc. With the additional parameter of frequency, however, the dielectric technique provides more insight to the segmental motions of the molecule and relaxation phenomena. This presentation describes the apparatus used in our laboratory for more than three years. Some applications will be shown.

EXPERIMENTAL

Although standard instrumentation is available for dielectric testing, efforts have been made to devise special test cells and electronic components to construct a complete and compact unit to allow rapid dynamic monitoring of dielectric parameters as a function of temperature. Also, we intend to build an ETA unit as a plug-in module of a commercially available thermal analyzer in order to perform multi-functions. In the present work, the DuPont 900 thermal analysis system is chosen because of its versatility and easy adaptation. The DuPont system has a 960 ETA module on test marketing, which can perform resistivity measurements on powdered or liquid samples. Our present sample holder assembly can be readily connected to the DuPont 960 to perform resistivity measurements on film samples.

A block diagram for the components needed for automatic dielectric measurements is shown in Fig. 1. The temperature of the sample holder assembly is controlled by the temperature programmer in the DuPont 900 thermal analyzer console through

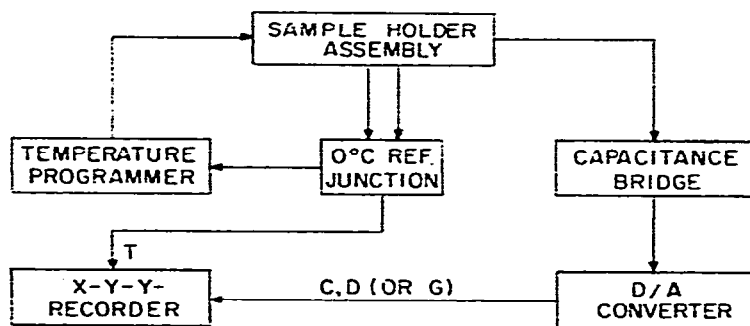

Fig. 1. Block diagram of ETA apparatus.

a thermocouple feed-back loop. The sample holder assembly is connected to a General Radio automatic capacitance bridge, Type 1680-A, which provides digital output signals of both capacitance (C) and dissipation factor (D) or conductance (G) automatically and continuously. This bridge has three fixed frequencies, 120, 400 and 1000 Hz. General Radio also markets an automatic bridge, Type 1682, with a frequency of 1 MHz which may be desirable for some types of work. The digital signals are visually displayed, and converted to analog signals by General Radio Type 1136-A D/A converters or equivalent such as slightly modified Hewlett-Packard 580A converters. Both capacitance and dissipation factor are then recorded on a Moseley 136-A X-Y-Y recorder. The sample holder assembly is connected to the DuPont 900 thermal analyzer through an isothermal time base accessory (DuPont Cat. No. 900433). The temperature signal is taken from this accessory and fed to the X-Y-Y recorder. The reference junctions of the sample and the control thermocouples are placed in an icepoint reference standard unit (Type 2110, Joseph Kaye & Co., Cambridge, Mass.) to maintain a constant temperature of 0.01°C automatically.

A schematic drawing of the sample holder assembly is shown in Fig. 2. It is built around a DuPont 941 thermomechanical analyzer (TMA) module to utilize its heating system and temperature control. An electrode assembly with details shown in Fig. 3 replaces the original TMA probe. The TMA transducer is not removed, however, thus providing a potential for simultaneous TMA-ETA. A Dewar larger than the one supplied with the TMA unit is required to accommodate the present ETA assembly for low temperature operations, and is shown in Fig. 4. A sample disc of a diameter of $\frac{3}{8}$ inch or smaller, either silver-painted or plain, is sandwiched between two stainless steel electrodes. If contamination of the electrodes is expected, an aluminium or tin foil disc is placed between the sample and the bottom electrode, and a standard aluminum sample pan used for DSC is placed between the sample and the top electrode. A suitable weight, normally 10 g, is positioned in the overhead tray to press down the top electrode against the sample. A thermocouple positioned close to one side of the sample provides accurate measurement of the sample temperature. A purge gas can be applied through a glass tubing into the sample chamber. The lead wires from the electrodes to the bridge are Teflon-insulated and shielded. Both the stainless steel screen, shielding

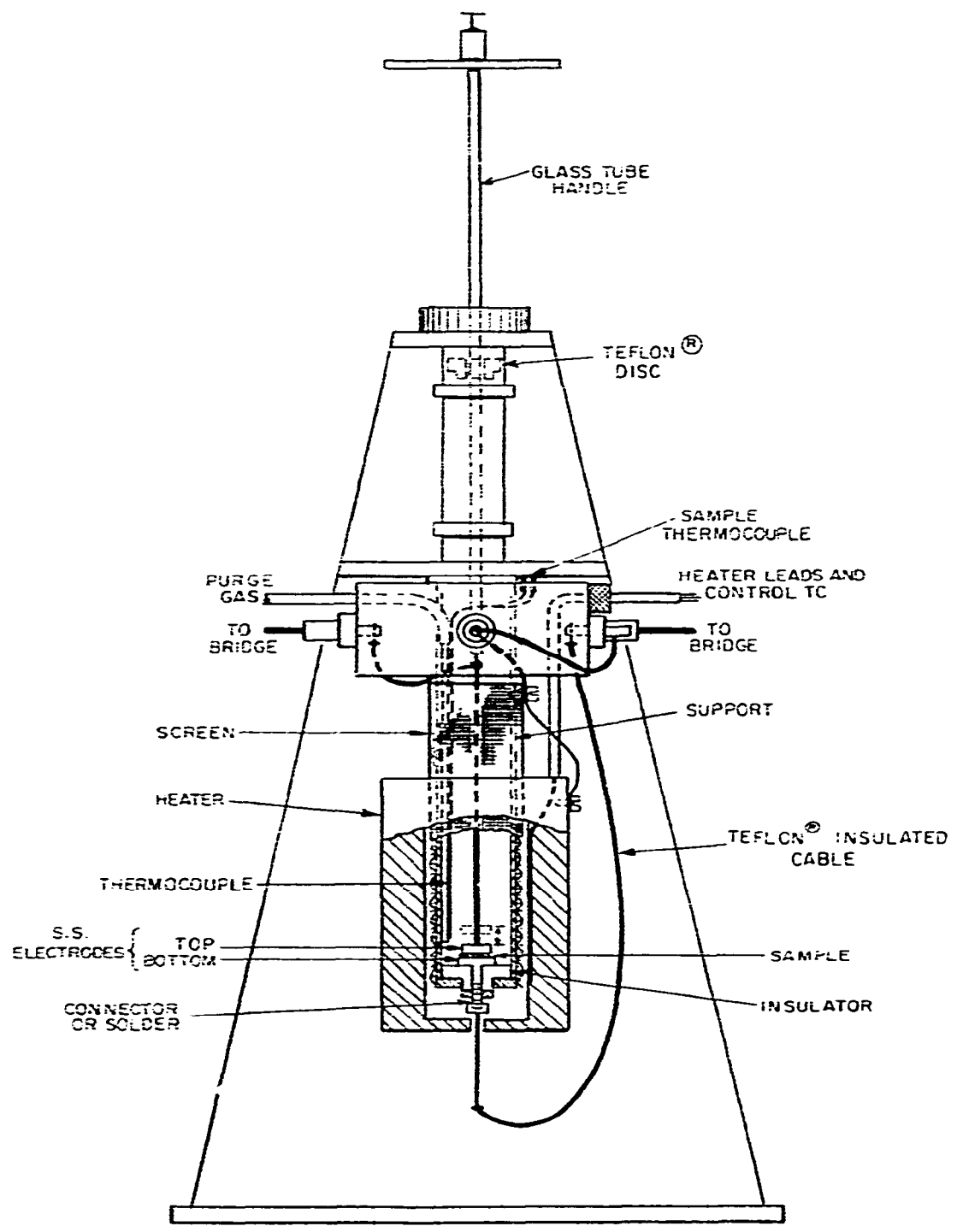

Fig. 2. Schematic diagram of ETA sample holder assembly.

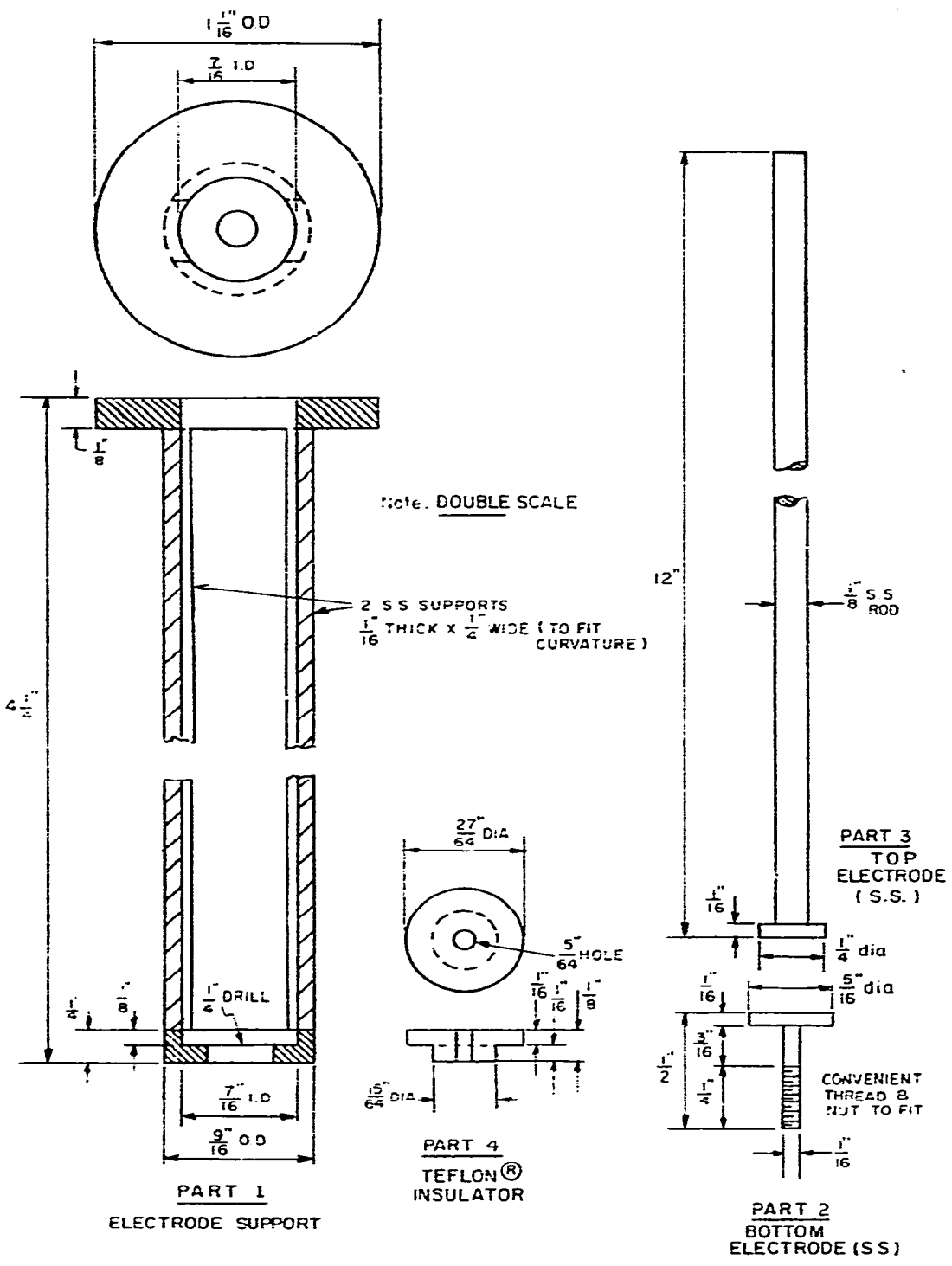

Fig. 3. ETA electrode system.

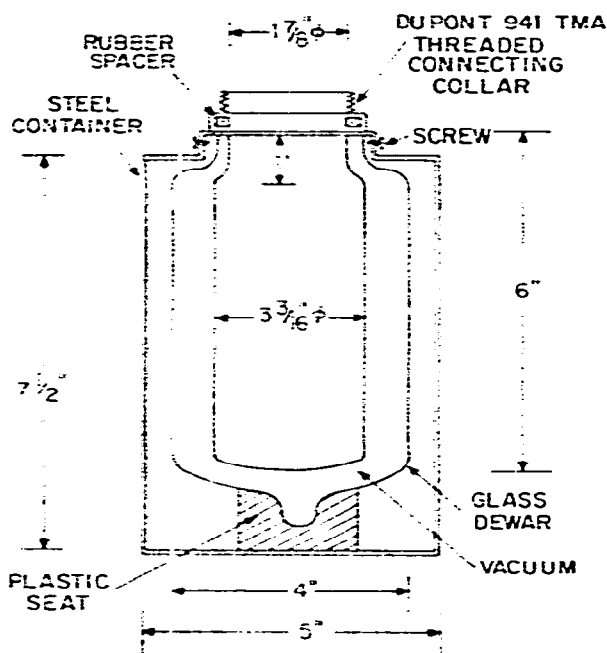

Fig. 4. Cooling dewar for ETA sample holder.

the sample chamber, and the cooling Dewar are grounded to prevent transient currents and electrical disturbances. The procedure for temperature control is essentially the same as that of TMA.

RESULTS AND DISCUSSION

A standard sample of potassium nitrate (Reference Material No. 756 from U.S. National Bureau of Standards) was analyzed by our ETA technique to check the temperature accuracy of the apparatus. The thermogram with dissipation factor and capacitance plotted simultaneously as a function of temperature is shown in Fig. 5. The crystalline transition observed at 129°C agrees well with the NBS average DTA value of 130°C and the thermodynamic value of 127.7°C. The crystalline transition and the melting transition of potassium nitrate are readily observed by DTA. However, ETA revealed some complexities of the crystalline transition, which could be attributed to disordering of the nitrate groups as suggested by Fermor and Kjekshus¹³. Also, a transition was detected by ETA at -20°C, which could be the same one observed at ca. -60°C by Fermor and Kjekshus¹⁴.

Poly(ethylene terephthalate) is a very interesting polymer for thermoanalytical studies, including DTA and electrical measurements. Our ETA technique is particularly useful because of its small sample requirements, automatic and continuous recording, and thermal treatment in situ. Typical ETA scans (only dissipation factor curves shown), for a commercial Mylar[®] film used for engineering drawing are shown in Fig. 6 for samples as received, quenched in liquid nitrogen from the molten state,

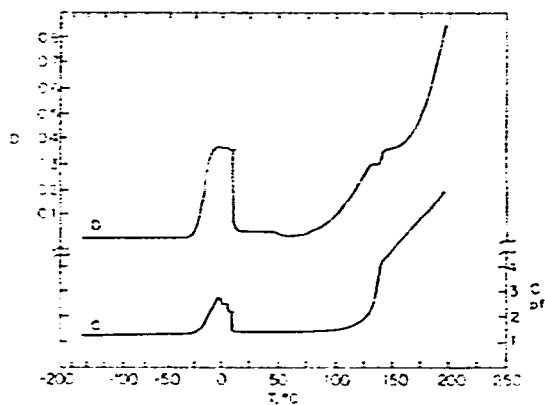

Fig. 5 (left). ETA scans of KNO_3 . Sample weight, 90 mg; sample dimensions, 0.8×9 mm diameter; heating rate, $10^\circ\text{C min}^{-1}$; frequency, 1 KHz; recorder setting, 20 mV in^{-1} .

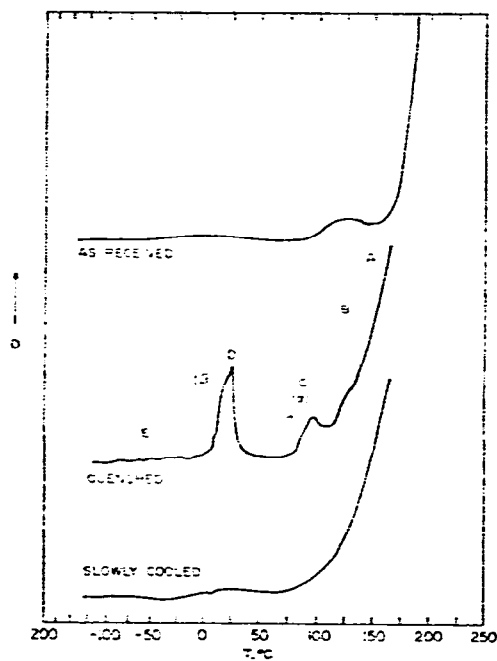

Fig. 6 (right). ETA scans of poly(ethylene terephthalate) films. Sample weight, 10 mg; sample dimensions, 0.1×9 mm diameter; heating rate, $10^\circ\text{C min}^{-1}$; frequency, 1 KHz; recorder setting, 20 mV in^{-1} .

and slowly cooled at 1°C min^{-1} from the melt, respectively. Obviously the various transitions observed are highly dependent on the pretreatment. For comparison, corresponding DTA scans obtained by a DuPont 990 thermal analyzer with a DSC attachment are shown in Fig. 7. Five regions of transitions were observed and marked on the thermograms in Figs. 6 and 7. Region A represents melting, and region B, cold crystallization of the polymer. Most workers agree that the glass transition or α -relaxation occurs in region C, involving micro-Brownian motions in the amorphous phase of the polymer. However, interpretations vary for the β -processes broadly including temperature regions D and E¹⁵. DTA does not provide any useful information in these regions. ETA shows two distinct loss peaks centering at temperatures of 20 and ca. -60°C , respectively, the intensities of which are highly dependent on thermal treatment. Sacher¹⁶ resolved a broad loss peak in this region into two components, using a DuPont 310 Curve Resolver, and named them β_1 - and β_2 -relaxations. These two processes were generally assigned to motions of the carboxylate group and the glycol linkages, respectively^{15,17}. Recently, however, Sacher¹⁸ proposed that these local mode relaxations arise from cooperative motions of several repeating units involving the trans and gauche isomers of the glycol linkages. Sacher¹⁹ also suggested an additional frequency-invariant loss in the glass transition region which could be visualized in our ETA scan.

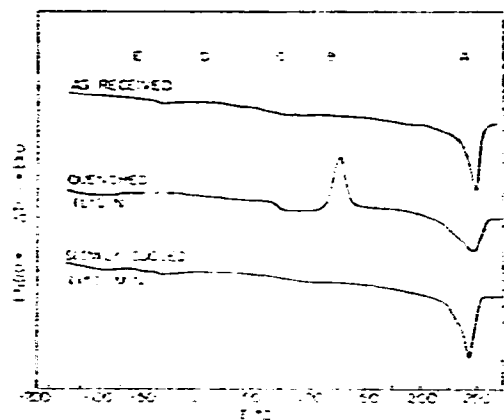

Fig. 7 (left). DTA scans of poly(ethylene terephthalate) films. Sample weight, 5 mg; heating rate, $10^{\circ}\text{C min}^{-1}$; reference, empty aluminum pan; ΔT sensitivity, $0.5^{\circ}\text{C in}^{-1}$.

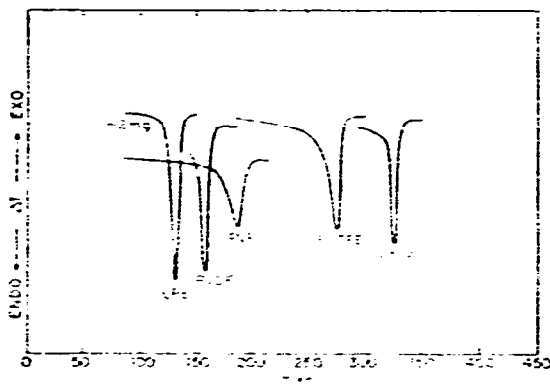

Fig. 8 (right). DTA scans of fluorocarbon polymers. Sample weight, ca. 10 mg (except PE); heating rate, $10^{\circ}\text{C min}^{-1}$; reference, empty aluminum pan; ΔT sensitivity, $0.5^{\circ}\text{C in}^{-1}$.

A group of fluorocarbon polymers with increasing substitution of hydrogen atoms in polyethylene by fluorine was analyzed by several thermal techniques including ETA. The samples included linear polyethylene (LPE), poly(vinyl fluoride) (PVF), poly(vinylidene fluoride) (PVDF), a 1/1 ethylene-tetrafluoroethylene copolymer (E TFE), and polytetrafluoroethylene (PTFE). As shown by the DTA curves in Fig. 8, each polymer shows its characteristic melting endotherm at a certain temperature which can be used for identification. However, identification based on melting point is by no means specific. Any other polymer with similar melting temperatures cannot be distinguished: for instance, polypropylene melts in the same temperature region as poly(vinylidene fluoride). Melting temperatures can also be altered by the presence of either internal or external plasticizers. Weight loss curves obtained by DuPont 951 thermogravimetric analyzer, shown in Fig. 9, provide additional characterization. Polymers such as poly(vinylidene fluoride) behave quite differently in thermal decomposition as compared with polyethylene or polypropylene. The polyolefins are completely volatilized, while poly(vinylidene fluoride) produces a carbonaceous residue which can be combusted in the presence of air. Again, the thermogravimetric technique has its limitations. For instance, it does not distinguish poly(vinylidene fluoride) from a carbon-filled polyethylene. In cases like this, additional dielectric measurements can be very helpful. As shown in Fig. 10, the more polar polymers, poly(vinylidene fluoride) and poly(vinyl fluoride), show characteristic dielectric loss peaks, clearly distinguishable from the relatively featureless and low loss curves of the other fluorocarbon polymers.

The dielectric behavior of poly(vinyl fluoride) has been reviewed by McCrum et al.¹⁵ The authors summarized previous dielectric and mechanical data, and suggested a high-temperature α -peak or glass transition above room temperature and a low-temperature β -peak at ca. -20°C due to local chain motions. Sacher²⁰ disagreed

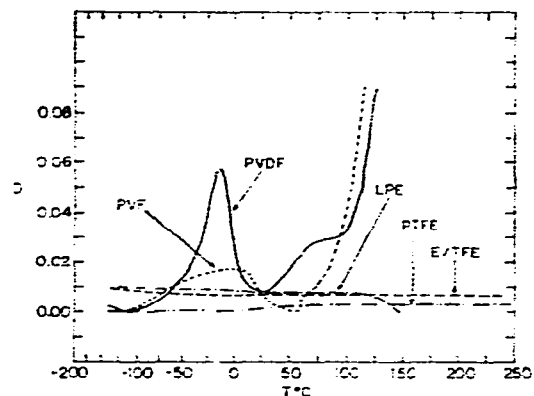
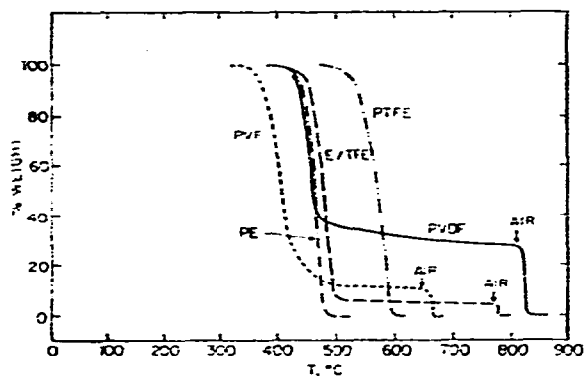

Fig. 9 (left) TG scans of fluorocarbon polymers. Sample weight, 20 mg; heating rate, $5^{\circ}\text{C min}^{-1}$; atmosphere, nitrogen flow at 60 ml min^{-1} ; sensitivity, 4 mg in^{-1} .

Fig. 10 (right). ETA scans of fluorocarbon polymers. Sample weight, 10–20 mg; sample dimensions, $0.1 \times 9\text{ mm}$ diameter, heating rate, $10^{\circ}\text{C min}^{-1}$; frequency, 1 KHz; recorder setting, 20 mV in^{-1} .

with this conclusion, and assigned the high-temperature process to a d.c. conduction mechanism, and the low-temperature process to the glass transition. Our ETA scans indicate the presence of a broad low-temperature loss peak in the range -120 – 50°C , probably including overlapped peaks at ca. -25 and 0°C , respectively, and also a high-temperature loss peak beginning at ca. 55°C with an overlapped peak at ca. 70°C . These results, combined with DTA curves shown in Fig. 11, seem to support Sacher's assignment, and indicate a glass transition at -25°C , a first-order transition at 50°C , gradual melting at higher temperatures, and local motions at temperatures below -25°C .

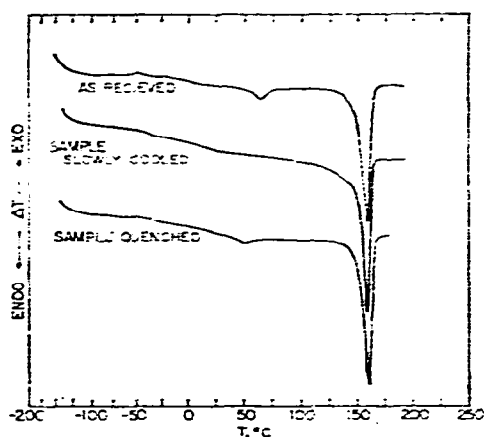
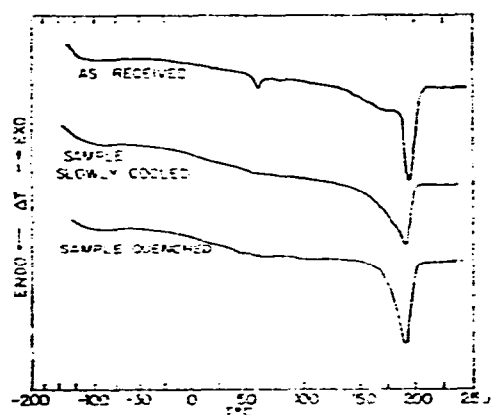

Fig. 11 (left). DTA scans of poly(vinyl fluoride). Sample weight, 5 mg; heating rate, $20^{\circ}\text{C min}^{-1}$; reference, empty aluminum pan; ΔT sensitivity, $0.5^{\circ}\text{C in}^{-1}$.

Fig. 12 (right). DTA scans of poly(vinylidene fluoride). Sample weight, 5 mg; heating rate, $20^{\circ}\text{C min}^{-1}$; reference, empty aluminum pan; ΔT sensitivity, $0.5^{\circ}\text{C in}^{-1}$.

McCrum *et al.*¹⁵ also discussed the two dielectric relaxation regions for poly(vinylidene fluoride). The low-temperature loss peak in the range -10 to -40°C was attributed to the glass transition, while the high-temperature peak above room temperature was associated with the crystalline phase. More recent work²¹⁻²⁴ established four regions of relaxation for poly(vinylidene fluoride), namely, molecular motions in the crystalline phase for the β -form above 100°C , molecular motions in the crystalline phase for the α -form at ca. 70°C , micro-Brownian motions of the amorphous main chains at ca. -20 to -40°C , and local oscillations in the amorphous region below -40°C . All these four processes are shown in the ETA scan in Fig. 10. A comparative DTA scan is shown in Fig. 12. Thus, our ETA and DTA results indicate the behaviour of poly(vinyl fluoride) closely parallels that of poly(vinylidene fluoride).

A potential application of ETA is in discrimination between copolymers and homopolymer blends. This is illustrated by styrene and methyl methacrylate polymer systems. Figure 13 shows dissipation factor versus temperature curves for polystyrene (PS), polymethyl methacrylate (PMMA), a blend of 40/60 PS-PMMA, and a 40/60

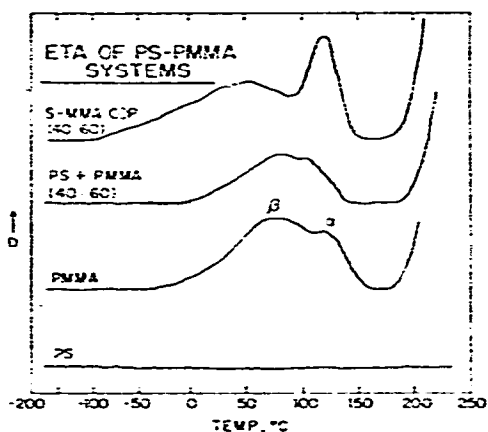

Fig. 13. ETA scans of polystyrene-poly(methyl methacrylate) systems. Sample weight, ca. 10 mg; sample dimensions, 0.1×9 mm diameter; heating rate, $10^{\circ}\text{C min}^{-1}$; frequency, 1 KHz; recorder setting, 20 mV in^{-1} .

styrene-methyl methacrylate copolymer. The dielectric loss of polystyrene is very low, and its ETA scan is essentially featureless. The ETA scan of PMMA clearly shows the α -relaxation or glass transition, and the β -transition due to motions of the polar side chains¹⁵. ETA also provides a means to determine the plastic flow temperature above the glass transition for amorphous polymers which is not detectable by DTA. The ETA scan of the physical blend of PS and PMMA shows simply the summation of the scans of the individual polymers. However, in the case of the copolymer, ETA shows a small depression of the α -transition temperature, but a large depression of the β -transition, thus resulting in a much enhanced resolution of the two loss peaks. The intensity of the α -transition is also increased. These features can be used to distinguish

a copolymer from a blend. DTA detects only the α -transition, and cannot distinguish among PS, PMMA, their blend, or copolymers.

CONCLUSION

A technique for dynamic electrothermal analysis based on dielectric measurements has been described, and can be readily adapted to commercially available thermal analyzers. Such an electrothermal technique is not a differential measurement, and, therefore, is not subject to heating rate restrictions, sloping baseline problems, reference material requirements, etc. The sensitivity of ETA is orders of magnitude higher than that of DTA in many occasions. The added dimension of dielectric relaxation associated with structure should provide a valuable tool for materials characterization.

REFERENCES

- 1 W. W. Wendlandt, *Thermal Methods of Analysis*, Interscience, New York, 1964, p. 387.
- 2 P. D. Garn, *Thermoanalytical Methods of Investigation*, Academic Press, New York, 1965, p. 379.
- 3 R. W. Warfield, in J. V. Schmitz (Ed.), *Testing of Polymers*, Vol. 1, Interscience, New York, 1965.
- 4 D. A. Seanor, *Tech. Methods Polym. Eval.*, 2 (1970) 293.
- 5 C. B. Murphy, *Anal. Chem.*, 36 (1964) 347R; 38 (1966) 443R; 40 (1968) 380R; 42 (1970) 268R; 44 (1972) 513R.
- 6 J. Mitchell, Jr. and Jen Chiu, *Anal. Chem.*, 43 (1971) 267R; 45 (1973) 273R.
- 7 N. S. Steck, *SPE Trans.*, 4 (1964) 34.
- 8 E. Sacher, *Rev. Sci. Instrum.*, 41 (1970) 1885; *J. Polym. Sci., A-2*, 10 (1972) 1179.
- 9 S. Yalof and W. Wrasidlo, *J. Appl. Polym. Sci.*, 16 (1972) 2159.
- 10 P. Hedvig and M. Kisbenyi, *Angew. Makromol. Chem.*, 7 (1969) 198.
- 11 P. Hedvig and T. Czvikovszky, *Angew. Makromol. Chem.*, 21 (1972) 79.
- 12 J. Galand, *Rev. Gen. Elec.*, 77 (10) (1968) 977.
- 13 J. H. Fermor and A. Kjekshus, *Acta Chem. Scand.*, 21 (1967) 1265.
- 14 J. H. Fermor and A. Kjekshus, *Acta Chem. Scand.*, 22 (1968) 836.
- 15 N. G. McCrum, B. E. Read and G. Williams, *Anelastic and Dielectric Effects in Polymeric Solids*, Wiley, London, 1967.
- 16 E. Sacher, *J. Polym. Sci., A-2*, 6 (1968) 1935.
- 17 K. H. Illers and H. Breuer, *J. Colloid Sci.*, 18 (1963) 1.
- 18 E. Sacher, *J. Macromol. Sci.*, B5 (1971) 739.
- 19 E. Sacher, *J. Polym. Sci., A-2*, 10 (1972) 1179.
- 20 E. Sacher, *J. Polym. Sci., A-2*, 6 (1968) 1813.
- 21 H. Sasabe, S. Saito, M. Asahina and H. Kakutani, *J. Polym. Sci., A-2*, 7 (1969) 1405.
- 22 H. Kakutani, *Kobunshi Kagaku*, 26 (285) (1969) 83; *J. Polym. Sci., A-2*, 8 (1970) 1177.
- 23 N. Koizumi, S. Yano and K. Tsunashima, *J. Polym. Sci.*, B7 (1969) 59.
- 24 S. Yano, *J. Polym. Sci., A-2*, 8 (1970) 1057.